



INFINITY
SERIES



Y2K
Year 2000
Compliant

Made in the USA

INFCS **INFINITYSM C Strain Gage Meter**

NEWPORTnetSM On-Line Service
<http://www.newportinc.com>

Internet e-mail
info@newportinc.com

**For immediate technical or application assistance
please call:**

1-800-6397678SM
1-800-NEWPORT

Newport Electronics, Inc.

2229 South Yale Street • Santa Ana, CA • 92704-4426 • U.S.A.
TEL: (714) 540-4914 • FAX: (714) 546-3022
Toll Free: 1-800-639-7678 • e-mail: info@newportinc.com

Newport Technologies, Inc.

976 Bergar • Laval (Quebec) • H7L 5A1 • Canada
TEL: (514) 335-3183 • FAX: (514) 856-6886
Toll Free: 1-800-639-7678 • e-mail: info@newport.qc.ca

Newport Electronics, Ltd.

One Omega Drive • River Bend Technology Centre
Northbank, Irlam, • Manchester, M44 5EX, England
Tel: 44 (161) 777-6611 • FAX: 44 (161) 777-6622
Toll Free: 0800-488-488 • e-mail: info@newportinc.co.uk

Newport Electronics B.V.

Postbus 8034 • 1180 LA Amstelveen • The Netherlands
TEL: (31) 20 6418405 • FAX: (31) 20 6434643
Toll Free: 0800 0993344 • e-mail: nl@newportinc.com

Newport Electronics spol s.r.o.

ul. Rude armady 1868, 733 01 Karvina-Hranice • Czech Republic
TEL: 420 (69) 6311899 • FAX: 420 (69) 6311114
Toll Free: 0800-1-666432 • e-mail: info@newport.cz

Newport Electronics GmbH

Daimlerstrasse 26 • D-75392 Deckenpfronn • Germany
TEL: 49 (07056) 3017 • FAX: 49 (07056) 8540
Toll Free: 0130 11 21 66 • e-mail: info@newport.de

Newport Electronique S.A.R.L.

9, rue Denis Papin • 78190 Trappes • France
TEL: (33) 130-621-400 • FAX: (33) 130-699-120
Toll Free: 0800-4-63978 • e-mail: france@newportinc.com

Mexico and Latin America

TEL: 95-800-639-7678 • FAX: 95-203-359-7807
En Español: (203) 359-7803 • e-mail: espanol@newportinc.com

START HERE

Using This Quick Start Manual

Use this Quick Start Manual to set up your Strain Gage Meter and begin operation. Information is provided on how to:

- Connect ac power
- Connect the sensor
- Set basic options for operation
- Scale the meter.

For complete information on all setup options, please refer to the Strain Gage Meter Operator's Guide.

NOTE

This Quick Start Manual includes specific configuration parameters for bridge sensors with an output range of 0—100 mV and 10 V excitation. Other sensor types may require different parameters or additional ones. When this is the case, we refer you to the Operator's Manual for detailed instructions.

Before You Begin

In addition to the meter and the related parts, you will need the following items to set up your unit:

- 110 Vac power
- Sensor
- 1/8-inch flat-blade screwdriver.

Mount the Unit

1. Cut a panel opening using the dimensions shown below.

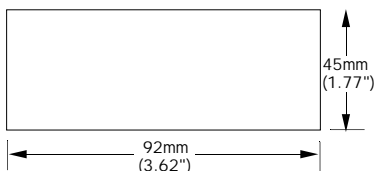

2. Position the unit in the opening, making sure the front bezel is flush with the panel.
3. Install retaining clips on both sides of the meter and tighten against the panel.

Connect AC Power

1. Remove the panel at the back of the unit.
2. Locate the TB1 connector.

2

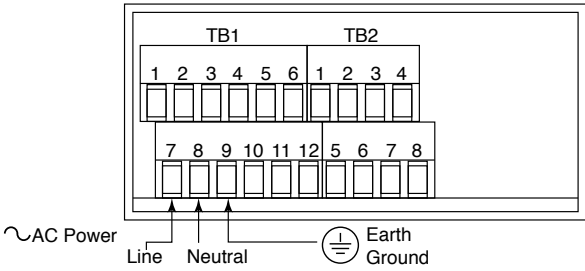

Main AC Power Connections

3. Insert the correct wire in each terminal as shown in the figure above and tighten the lockdown screws.
4. Tug gently on the wires to verify the connections.

Connect the Sensor

1. Locate the TB2 connector on the rear of the unit.
2. Attach the sensor wires and tighten the lockdown screws.

The diagram below shows the wiring for bridge sensors with internal excitation. Refer to the Operator's Manual for setup requirements for other sensor types.

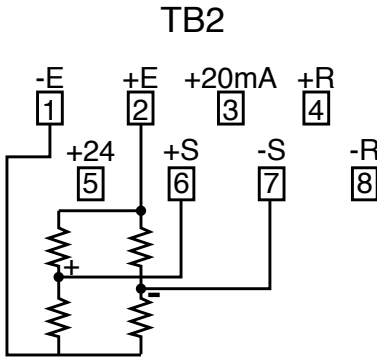

Bridge Sensor with Internal Excitation

3. Tug gently on the wires to verify the connections.
4. Replace the panel at the back of the unit.

Turn On the Unit

1. Apply ac power.

As the unit initializes, RST flashes on the front panel, and then a numeric reading is displayed.

3

2. Verify that a numeric reading is displayed. If not:

- ¥ Remove ac power
- ¥ Verify the TB1 power connections
- ¥ Check your power source
- ¥ Apply ac power again.

Using the Configuration Menu

To configure the meter, you use the buttons on the front panel.

| To: | Take This Action: |
|--|--|
| Display the Configuration Menu | Press the MENU button. The first function on the menu, INPT, displays. |
| Select a submenu function | 1. Press MENU until the function you want is shown. 2. Press ► /TARE. The information you can change flashes. |
| Select a value for that submenu function | 1. Press ▲ NT/GRS to display the option you want. 2. Press MENU to store it. "STRD" quickly flashes, indicating that the selection has been stored in memory. Then the next menu function displays. |
| Go back to the previous menu function | Press RESET once. |
| Exit the Configuration Menu | ¥ Press RESET twice. The unit displays "RST" as it reinitializes. When a numeric value displays, the unit is in the run mode. ¥ Optionally, you can press MENU to move through all the menu functions until the unit reinitializes. |

To Set the Input Type

1. Press MENU until the unit displays
2. Press ► /TARE. The unit displays:

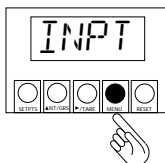

3. For this application you want 100M. If 100M is not displayed, press ▲ NT/GRS until it appears. Other choices are 50 m, 10 V, 5 V, 0—20. Refer to the Operator's Manual for more information on changing ranges.

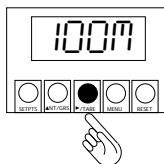

4

4. Press MENU to select the sensor shown. The meter displays the next menu item. If you changed input type, the meter displays:

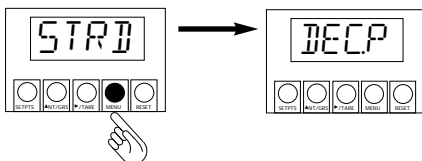

To Set the Decimal Point

1. If it's not already shown, press MENU until the unit displays:

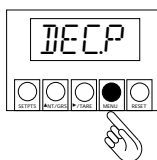

2. Press ▶ /TARE. The unit displays:

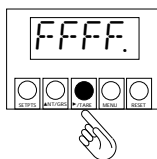

3. Press ▲ NT/GRS to move the decimal point to the desired location. The factory setting is FFFF. The other choices are FFF.F, FF.FF, and F.FFF.

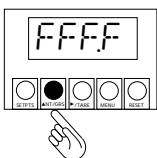

4. Press MENU to select the decimal point position shown. The unit displays:

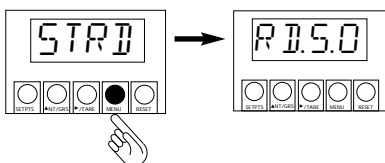

To Scale the Meter

You can scale the meter in one of two ways:

1. With a known load This method uses input (load) information sent from another device such as a scale or a simulator for voltage or current.
2. Without a known load This involves calculating the load based on transducer specifications and manually entering it to the meter.

To Set the Decimal Point

1. If it's not already shown, press MENU until the unit displays:

NOTE

The decimal point is for display purposes only you set it where you want it to display for your application. When entering IN1 and IN2 values, ignore any decimal point on the display. However, you must enter RD1 and RD2 vaules with the decimal point in the desired position.

2. Press **▶** /TARE. The unit displays:
3. Press **▲** NT/GRS to move the decimal point to the desired location. The factory setting is FFFF. The other choices are FFF.F, FF.FF, and F.FFF.

4. Press MENU to select the decimal point position shown. The unit displays:

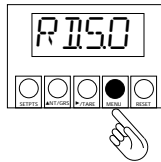

To Scale the Meter

You can scale the meter in one of two ways:

1. With a known load This method uses input (load) information sent from another device such as a scale or a simulator for voltage or current.
2. Without a known load This involves calculating the load based on transducer specifications and manually entering it to the meter.

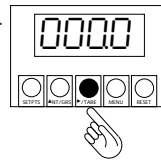
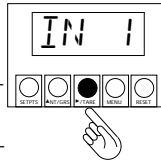

To Scale the Meter (continued)

For both methods, you must first identify the minimum input load (IN1) and the corresponding display reading you want (RD1). Then you identify the maximum input load (IN2) and its corresponding display reading (RD2).

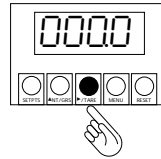

Scaling With Known Loads

To identify the minimum known load (IN1 and RD1):

1. If it's not already shown, press MENU until the unit displays:
2. Apply the minimum known load (0%).
3. Press **▶** /TARE. The unit displays:
4. Press **▶** /TARE again. The unit displays the last setting for IN1.
5. Press **▶** /TARE again. The unit displays the actual reading being received from the sending device.
6. Press MENU to store IN1. The unit displays:

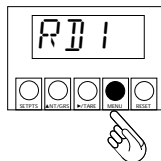

7. Press **▶** /TARE. The unit displays the last setting for RD1.

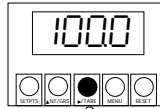

8. Change RD1 as necessary:

¥ Press **▶** /TARE to scroll to the digit(s) you want to change (it flashes on the display).

¥ Press **▲** NT/GRS to change the value of the flashing digit. Values can range from 0 to 9. For the first digit, you can also enter a minus sign (—) or —1.

9. Press MENU to store the value shown for RD1. The unit displays:

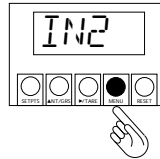

To identify the maximum known load (IN2 and RD2):

1. Apply the maximum known load (100%).
2. Repeat steps 4—9 for IN2 and RD2. Once you've completed all steps, the unit displays:

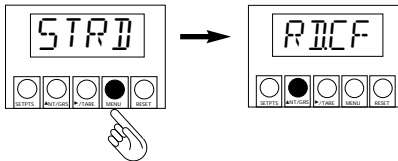

To begin operation:

Reinitialize the unit (press RESET twice or press MENU until RST flashes on the display). When a numeric reading appears, the unit is operational.

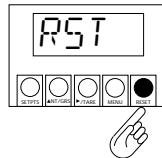

Scaling Without Known Loads

For 0–100 mV sensors, the values for the minimum and maximum input loads are always as follows:

- Minimum load (IN1) — 0
- Maximum load (IN2) — 9999.

If your installation uses a different sensor type, you must calculate the values for IN1 and IN2 before proceeding with the steps below. Use the formula provided in the Operator's Manual.

To define the minimum load (IN1 and RD1):

1. If it's not already shown, press MENU until the unit displays:

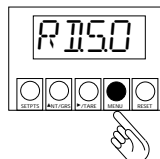

7

2. Press **▶** /TARE. The unit displays:

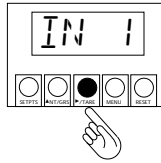

3. Press **▶** /TARE again. The unit displays the last setting for IN1. (The first digit flashes.)

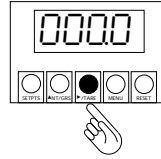

4. Change IN1 as necessary:

- ¥ Press **▲** NT/GRS to set or change the digit's current value. Continue to press **▲** NT/GRS until the meter displays the desired value for the flashing digit. Values can range from 0 to 9. For the first digit, you can also enter a minus sign (—) or —1.
- ¥ Press **▶** /TARE to scroll to the remaining digit(s) you want to change.

5. Press MENU to store IN1. The unit displays:

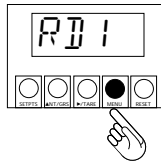

6. Press **▶** /TARE. The unit displays the last setting for RD1. (The first digit flashes.)

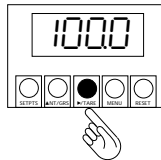

7. Change RD1 as necessary:

- ¥ Press **▲** NT/GRS until the meter displays the desired value for the flashing digit. Values can range from 0 to 9. For the first digit, you can also enter a minus sign (—) or —1.
- ¥ Press **▶** /TARE to scroll to the digit(s) you want to change.

8. Press MENU to store the value shown for RD1. The unit displays:

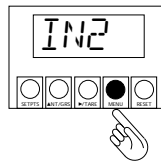

To define the maximum load (IN2 and RD2):

1. Repeat steps 3—9 above, entering the values for IN2 and RD2.

2. Once you've completed all steps, the unit displays:

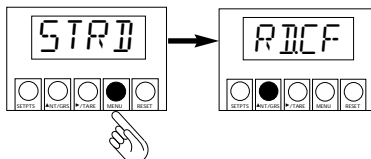

To begin operation:

Reinitialize the unit (press RESET twice or press MENU until RST flashes on the display).

When a numeric reading appears, the unit is operational.

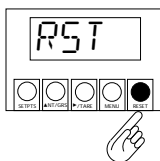

Determining Reading Offsets

Meters scaled without known loads may reflect an offset in run mode. For example, say you set RD1 to 0 and RD2 to 100, but when the minimum load is applied, a value of -1.5 displays on the front panel.

To correct the reading offset:

1. With zero load applied, note the reading on the display.
2. Subtract that amount from the RD1 and RD2 values you originally entered.

In the example, the offset would be -1.5 . If RD1 is to read 0 in run mode, it must be reentered as 1.5. RD2 must likewise be reentered as 101.5 if the meter is to read 100 when the maximum load is applied.

3. Repeat the steps for "Scaling Without Known Loads," but when the values for IN1 and IN2 display, do not change them. Instead, press MENU to move to the prompts for RD1 and RD2 and make the necessary changes.
4. Reinitialize the unit and resume operation.

It is the policy of Newport to comply with all worldwide safety and EMC/EMI regulations that apply. Newport is constantly pursuing certification of its products to the European New Approach Directives. Newport will add the CE mark to every appropriate device upon certification.



This device is marked with the international hazard symbol. It is important to read the Setup Guide before installing or commissioning this device as it contains important information relating to safety and EMC.

WARNING: These products are not designed for use in, and should not be used for, patient connected applications.

PATENT NOTICE: This product is covered by one or more of the following patents: U.S. No. Des. 336, 895; 5,274,577/ CANADA 2,052,600/ ITALY 1,249,456; 1,250,938/ SPAIN 2,039,150; 9,102,259/ UK GB2,249,837; 2,248,954/ FRANCE BREVET 9,112,756 / GERMANY DE 4134398C2.

TRADEMARK NOTICE:  **NEWPORT**

 **NEWPORT**, , **INFINITY**, and

INFINITY are trademarks of NEWPORT Electronics, Inc. The "Meter Case Bezel Design" is a trademark of NEWPORT Electronics, Inc., registered in the U.S.



Warranty/Disclaimer

NEWPORT ELECTRONICS, INC. warrants this unit to be free of defects in materials and workmanship for a period of one (1) year from the date of delivery. In addition to NEWPORT's standard warranty period, NEWPORT ELECTRONICS will extend the warranty period for one (1) additional year if the warranty card enclosed with each instrument is returned to NEWPORT.

If the unit should malfunction, it must be returned to the factory for evaluation. NEWPORT's Customer Service Department will issue an Authorized Return (AR) number immediately upon phone or written request. Upon examination by NEWPORT, if the unit is found to be defective it will be repaired or replaced at no charge. NEWPORT's WARRANTY does not apply to defects resulting from any action of the purchaser, including but not limited to mishandling, improper interfacing, operation outside of design limits, improper repair, or unauthorized modification. This WARRANTY is VOID if the unit shows evidence of having been tampered with or shows evidence of being damaged as a result of excessive corrosion; or current, heat, moisture or vibration; improper specification; misapplication; misuse or other operating conditions outside of NEWPORT's control. Components which wear are not warranted, including but not limited to contact points, fuses, and triacs.

NEWPORT is pleased to offer suggestions on the use of its various products. However, NEWPORT neither assumes responsibility for any omissions or errors nor assumes liability for any damages that result from the use of its products in accordance with information provided by NEWPORT, either verbal or written. NEWPORT warrants only that the parts manufactured by it will be as specified and free of defects. NEWPORT MAKES NO OTHER WARRANTIES OR REPRESENTATIONS OF ANY KIND WHATSOEVER, EXPRESSED OR IMPLIED, EXCEPT THAT OF TITLE, AND ALL IMPLIED WARRANTIES INCLUDING ANY WARRANTY OF MERCHANTABILITY AND FITNESS FOR A PARTICULAR PURPOSE ARE HEREBY DISCLAIMED. LIMITATION OF LIABILITY: The remedies of purchaser set forth herein are exclusive and the total liability of NEWPORT with respect to this product, whether based on contract, warranty, negligence, indemnification, strict liability or otherwise, shall not exceed the purchase price of the component upon which liability is based. In no event shall NEWPORT be liable for consequential, incidental or special damages.

CONDITIONS: Equipment sold by NEWPORT is not intended to be used, nor shall it be used: (1) as a "Basic Component" under 10 CFR 21 (NRC), used in or with any nuclear installation or activity; or (2) in medical applications or used on humans. Should any Product(s) be used in or with any nuclear installation or activity, medical application, or used on humans, or misused in any way, NEWPORT assumes no responsibility as set forth in our basic WARRANTY/ DISCLAIMER language, and additionally purchaser will indemnify NEWPORT and hold NEWPORT harmless from any liability or damage whatsoever arising out of the use of the Product(s) in such a manner.

Return Requests

Direct all warranty and repair requests/inquiries to the NEWPORT Customer Service Department. BEFORE RETURNING ANY PRODUCT(S) TO NEWPORT, PURCHASER MUST OBTAIN AN AUTHORIZED RETURN (AR) NUMBER FROM NEWPORT'S CUSTOMER SERVICE DEPARTMENT (IN ORDER TO AVOID PROCESSING DELAYS). The assigned AR number should then be marked on the outside of the return package and on any correspondence.

The purchaser is responsible for shipping charges, freight, insurance and proper packaging to prevent breakage in transit.

FOR **WARRANTY** RETURNS, please have the following information available BEFORE contacting NEWPORT:

1. P.O. number under which the product was PURCHASED,
2. Model and serial number of the product under warranty, and
3. Repair instructions and/or specific problems relative to the product.

FOR **NON-WARRANTY** REPAIRS, consult NEWPORT for current repair charges. Have the following information available BEFORE contacting NEWPORT:

1. P.O. number to cover the COST of the repair,
2. Model and serial number of product, and
3. Repair instructions and/or specific problems relative to the product.

NEWPORT's policy is to make running changes, not model changes, whenever an improvement is possible. This affords our customers to latest in technology and engineering.

© Copyright 1998 NEWPORT Electronics, Inc. All rights reserved. This documentation may not be copied, photocopied, reproduced, translated, or reduced to any electronic medium or machine-readable form, in whole or in part, without prior written consent of NEWPORT Electronics, Inc.